

<http://iceboy.a-singer.de/>
<https://sourceforge.net/projects/iceboy/>

Author: Michael Singer

Sheet: /
 File: wideboy.sch

Title: Wide-Boy64 AGB

Size: A4	Date: 2021-07-22	Rev: 1
KiCad E.D.A. kicad 4.0.6		Id: 1/10

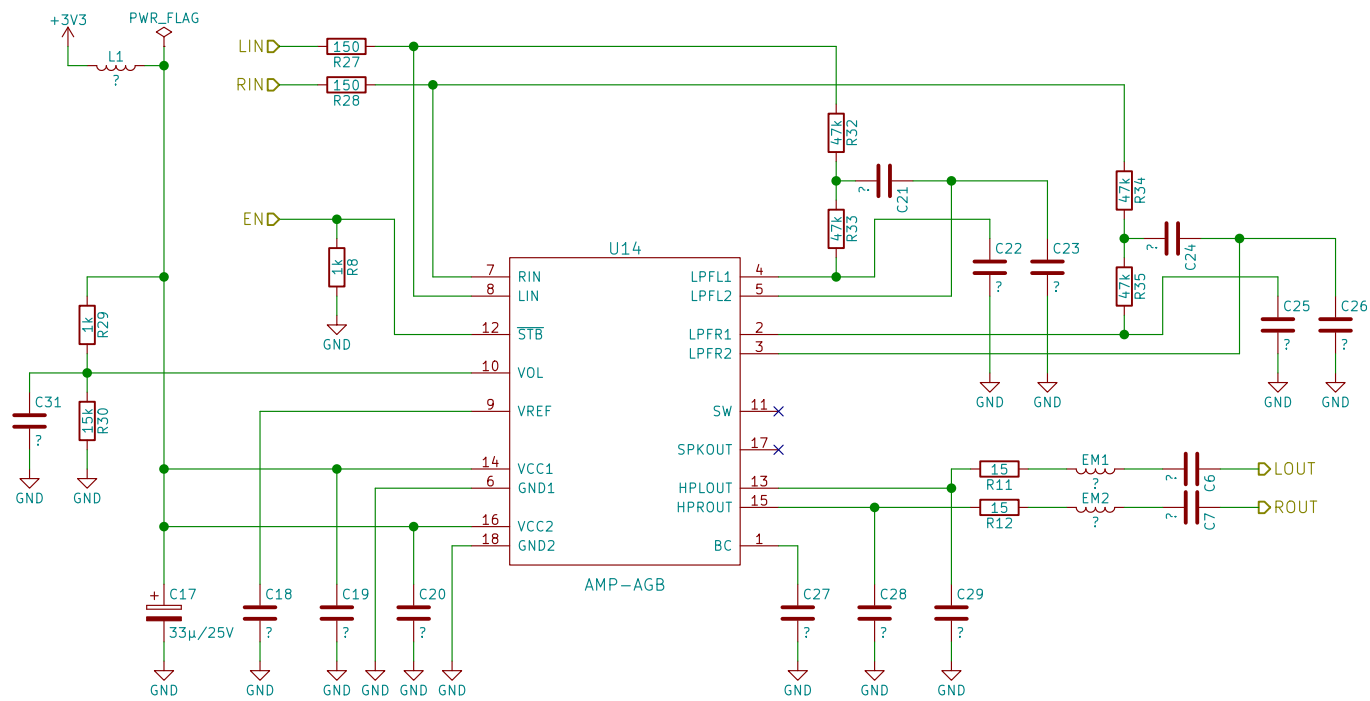

Place C19 close to VCC1 pin and ground side of C29.
 Place C20 close to VCC2 pin and ground side of C28.

<http://iceboy.a-singer.de/>
<https://sourceforge.net/projects/iceboy/>
Author: Michael Singer
 Sheet: /Amplifier/
 File: amp.sch

Title: Wide-Boy64 AGB

Size: A4 | Date: 2021-07-22
 KiCad E.D.A. kicad 4.0.6

Rev: 1
 Id: 2/10

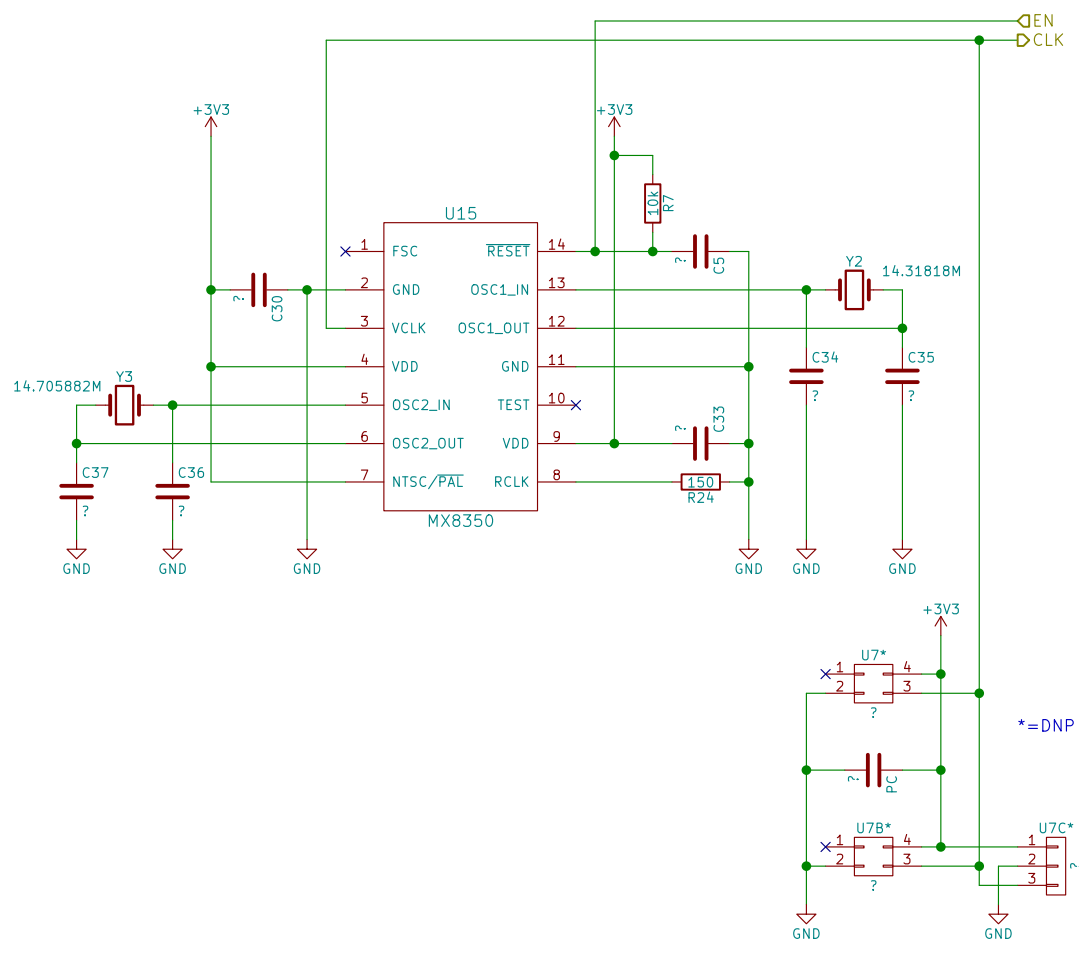

<http://iceboy.a-singer.de/>
<https://sourceforge.net/projects/iceboy/>
Author: Michael Singer

Sheet: /Clock Generation/
 File: clkgen.sch

Title: Wide-Boy64 AGB

Size: A4 Date: 2021-07-22
 KiCad E.D.A. kicad 4.0.6

Rev: 1
 Id: 3/10

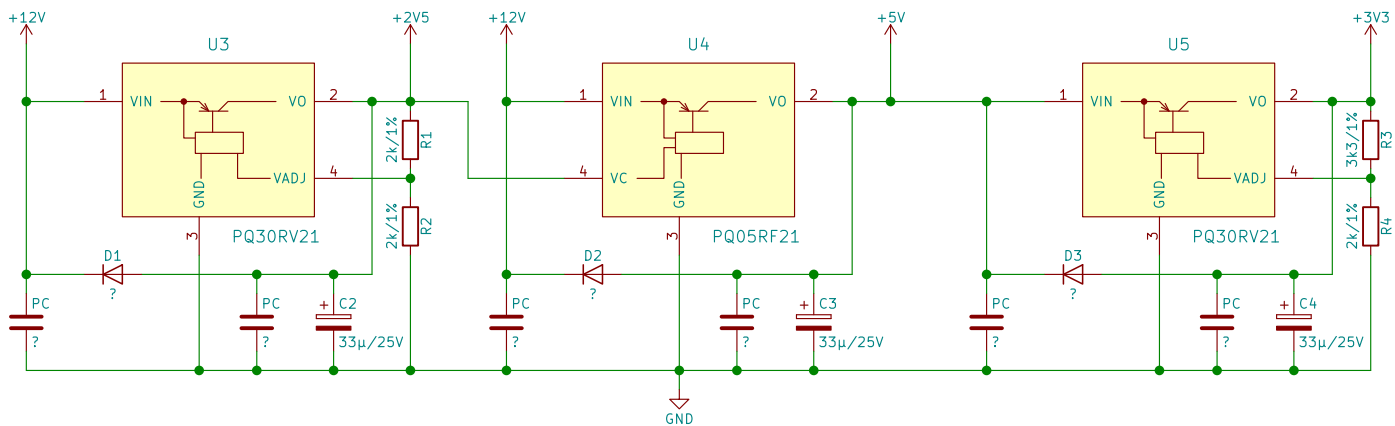

<http://iceboy.a-singer.de/>
<https://sourceforge.net/projects/iceboy/>

Author: Michael Singer

Sheet: /Power/

File: power.sch

Title: Wide-Boy64 AGB

Size: A4 Date: 2021-07-22

KiCad E.D.A. kicad 4.0.6

Rev: 1

Id: 4/10

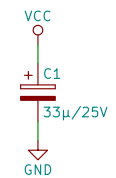
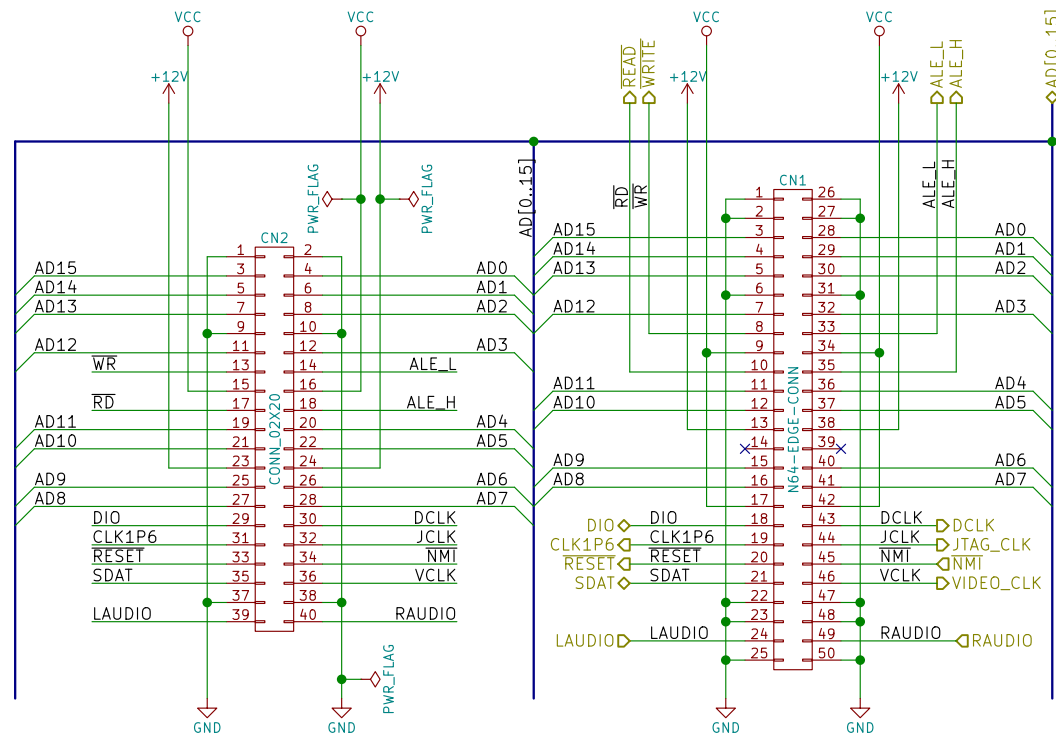

<http://iceboy.a-singer.de/>
<https://sourceforge.net/projects/iceboy/>

Author: **Michael Singer**

Sheet: /N64 Connector/

File: n64con.sch

Title: Wide-Boy64 AGB

Size: A4 Date: 2021-07-22

KiCad E.D.A. kicad 4.0.6

Rev: **1**

Id: 5/10

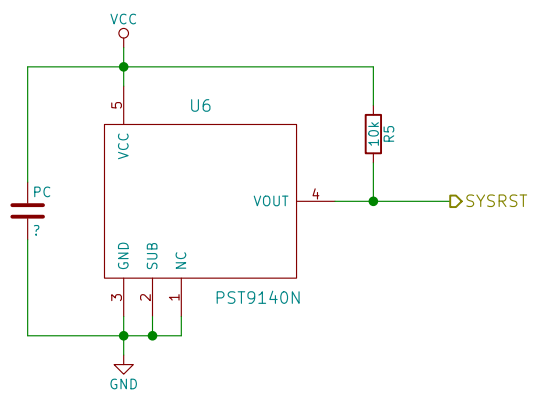
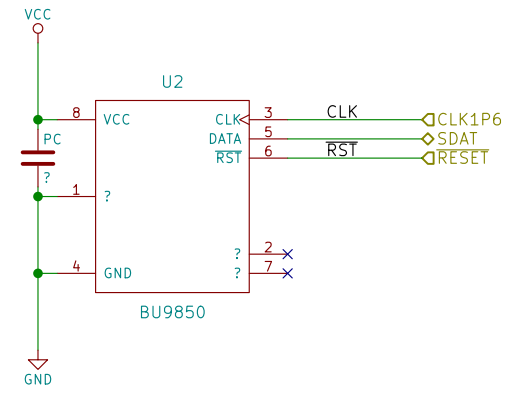
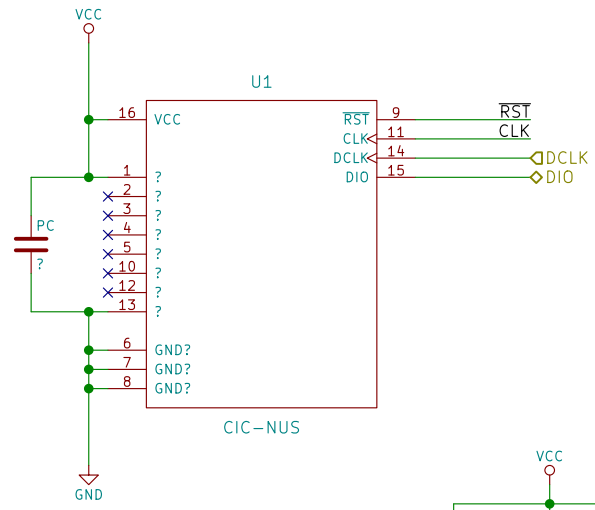

<http://iceboy.a-singer.de/>
<https://sourceforge.net/projects/iceboy/>

Author: Michael Singer

Sheet: /N64 Chips/
 File: n64chips.sch

Title: Wide-Boy64 AGB

Size: A4 Date: 2021-07-22

KiCad E.D.A. kicad 4.0.6

Rev: 1
 Id: 6/10

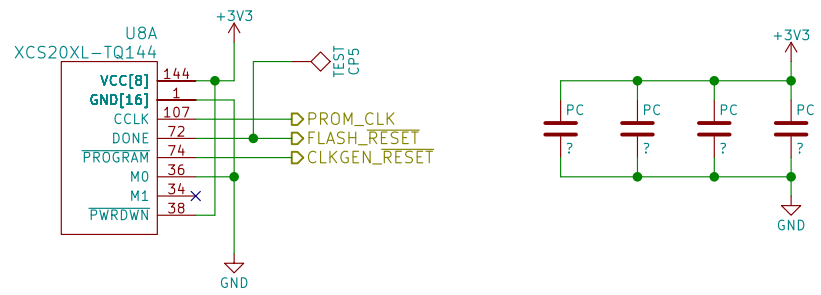
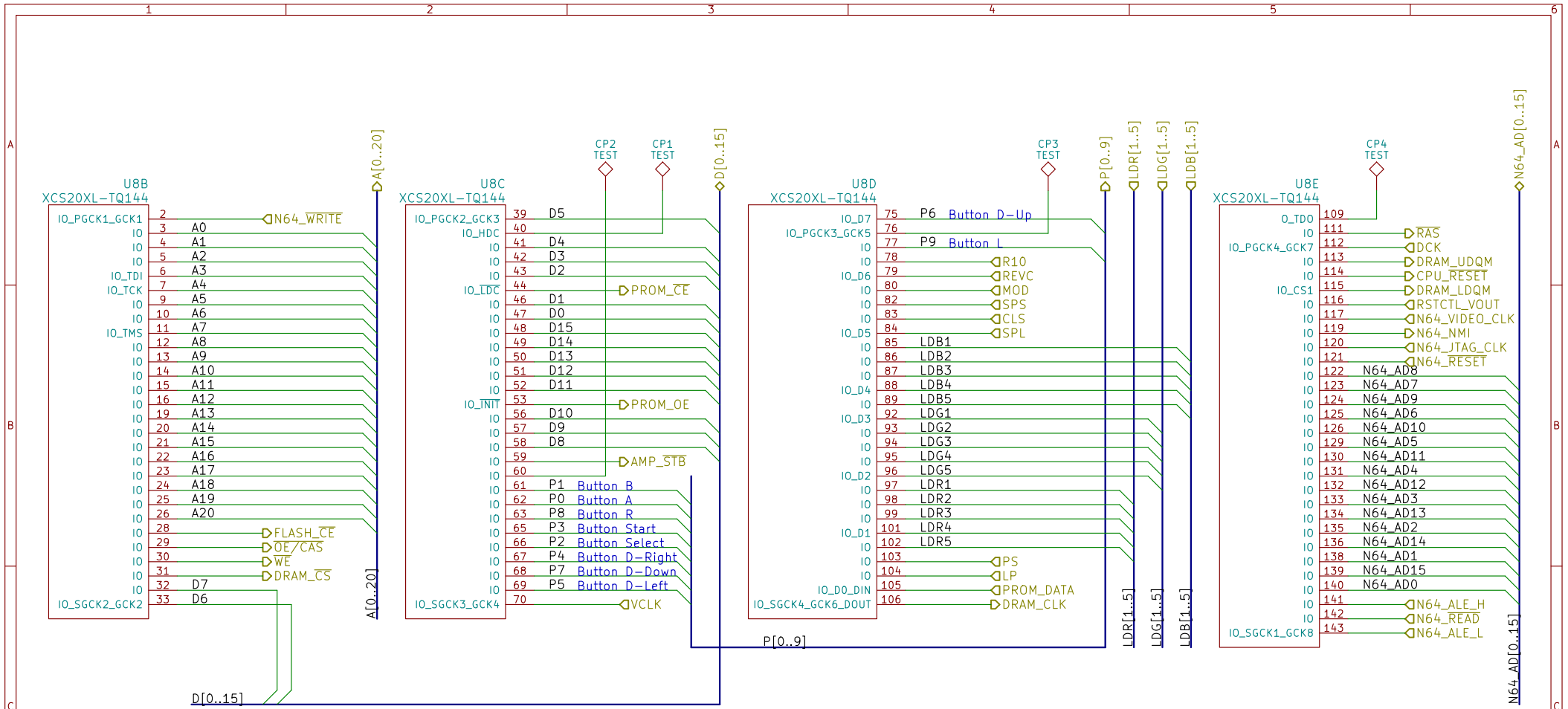

<http://iceboy.a-singer.de/>
<https://sourceforge.net/projects/iceboy/>
Author: Michael Singer
 Sheet: /FPGA/
 File: fpga.sch

Title: Wide-Boy64 AGB		
Size: A4	Date: 2021-07-22	Rev: 1
KiCad E.D.A. kicad 4.0.6		Id: 7/10

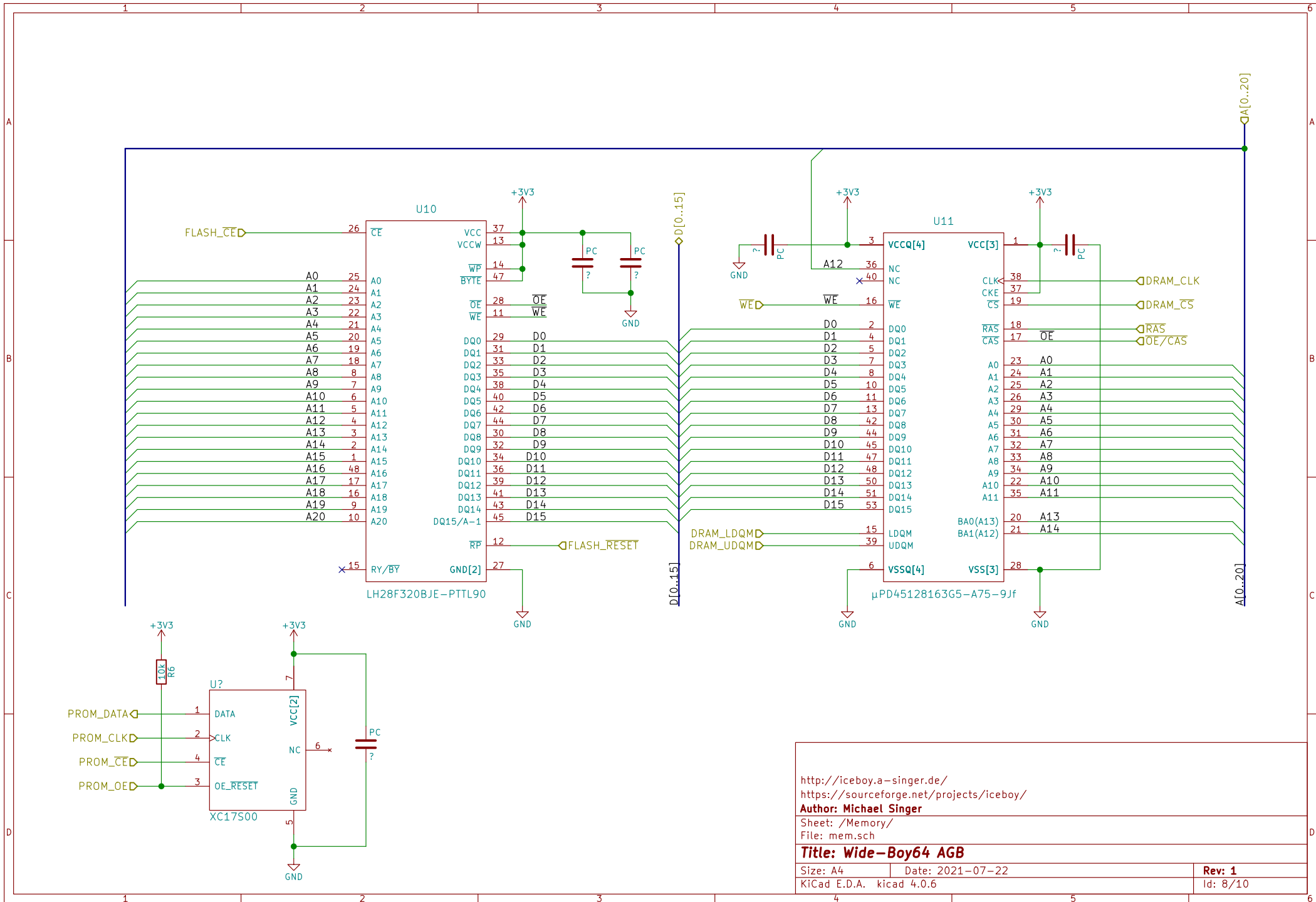

<http://iceboy.a-singer.de/>
<https://sourceforge.net/projects/iceboy/>

Author: Michael Singer

Sheet: /Memory/

File: mem.sch

Title: Wide-Boy64 AGB

Size: A4 Date: 2021-07-22

KiCad E.D.A. kicad 4.0.6

Rev: 1

Id: 8/10

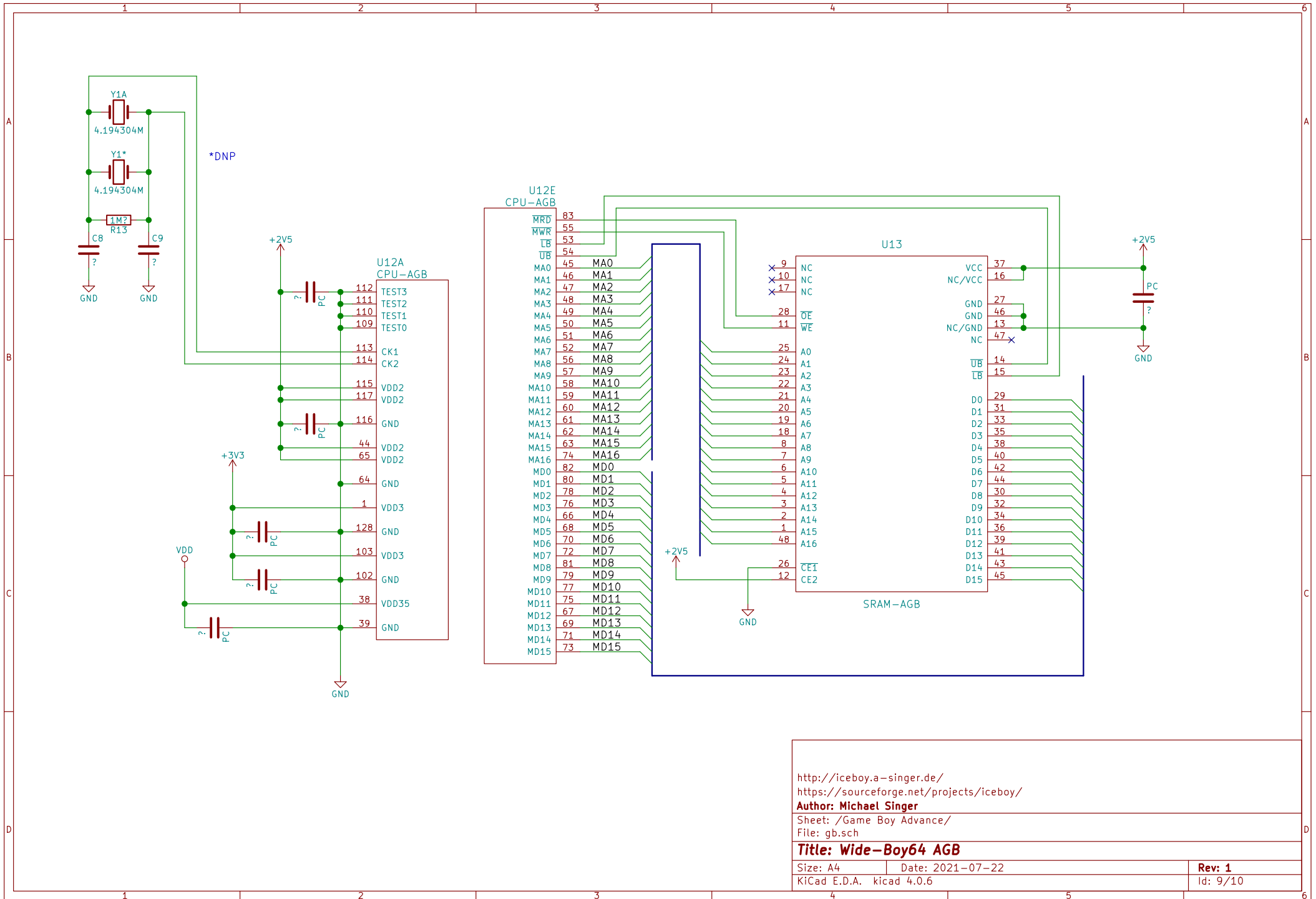

<http://iceboy.a-singer.de/>
<https://sourceforge.net/projects/iceboy/>

Author: Michael Singer

Sheet: /Game Boy Advance/
 File: gb.sch

Title: Wide-Boy64 AGB

Size: A4 Date: 2021-07-22

KiCad E.D.A. kicad 4.0.6

Rev: 1

Id: 9/10

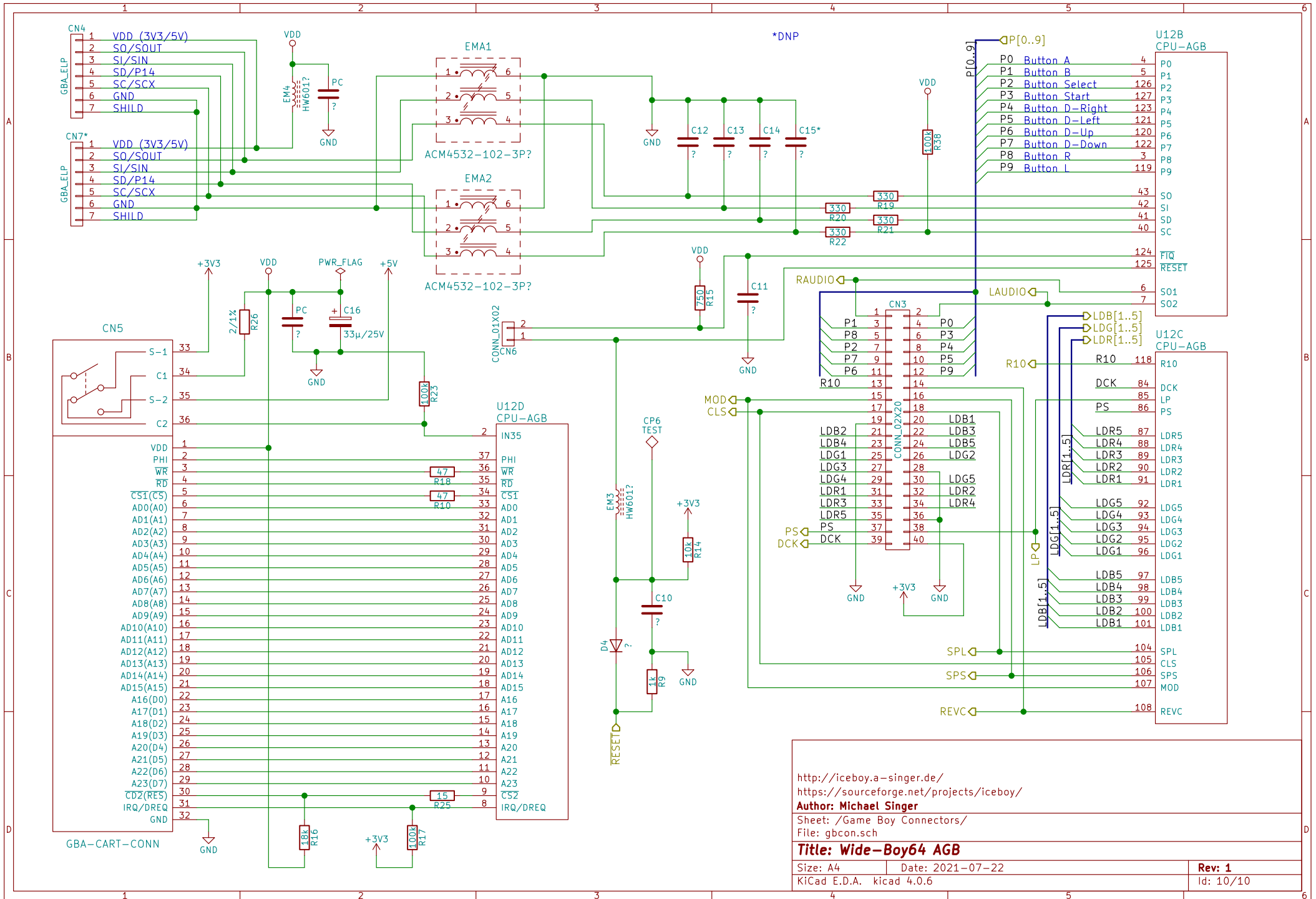

<http://iceboy.a-singer.de/>
<https://sourceforge.net/projects/iceboy/>

Author: Michael Singer

Sheet: /Game Boy Connectors/
 File: gbcon.sch

Title: Wide-Boy64 AGB

Size: A4 Date: 2021-07-22

KiCad E.D.A. kicad 4.0.6

Rev: 1

Id: 10/10